

# Measurements of the "Magnex DC" characteristics at microwave frequencies

Z. Q. BAKER\*, M. K. ABDELAZEEZ†, A. M. ZIHLIF\*

\*Physics Department and †Electrical Engineering Department, University of Jordan, Amman, Jordan

This paper deals with the measurements of the equivalent impedance, insertion loss (IL), and return loss (RL) of a conductive composite material called "Magnex DC", performed at microwave frequencies. It is found that the equivalent impedance of this composite material decreases as the frequency increases in the X-band (8–12.4 GHz) and the IL of a 1.4 mm thick specimen is greater than 9 dB over the whole band. The utilization of this material in electromagnetic shielding is considered. Furthermore, results of the measurements performed on a tapered specimen are also reported.

## 1. Introduction

The rapid growth in the utilization of electrical and electronic devices which emit electromagnetic energy in the same frequency bands used by other users makes it essential to limit and shield against all sources of interference. For example, this can be achieved by using a certain conductive polymer composite. This type of material has attracted the attention of material scientists, mainly due to its electromagnetic shielding effectiveness [1, 2]. Recently, several applications have appeared in the literature covering some theoretical [3] and experimental studies [1, 4] on polymer composites such as measurements of the shielding effectiveness [1] using the dual-chamber technique. Also, some studies were carried out on carbon fibre composites [5]. Measurement of the complex impedance using the slotted-line method is also reported [6].

In this paper, measurements of the "Magnex DC" impedance, insertion loss (IL), and return loss (RL), and the evaluation of its shielding effectiveness at microwave frequencies are given. Section 2 gives the experimental work performed on this material.

Results and discussion are given in Section 3 and the conclusion in Section 4.

## 2. Experimental work

The material used in this study, "Magnex DC", is produced by Diamond Shamrock Corp., Ohio, USA in the form of pellets. This material is an acrylonitrile-butadiene-styrene (ABS), a polymer matrix with stainless steel fibres as conductive fillers or reinforcement elements [7]. A scanning electron microscope (SEM) is used to examine the texture of this composite. A few composite pellets are dropped in liquid nitrogen and fractured parallel to their axis and fixed on sample stubs and coated with gold for examination under the SEM. The obtained micrographs are shown in Figs 1, 2, and 3. These figures reveal that the fibre diameter of the given composite is about 10  $\mu\text{m}$ . They also indicate that the fibres are embedded almost parallel to the pellet axis. The presence of voids spread in the composite matrix is also clear.

Sheets of 1.4 mm thickness are prepared from the pellets by the hot-pressing technique at 180°C. These

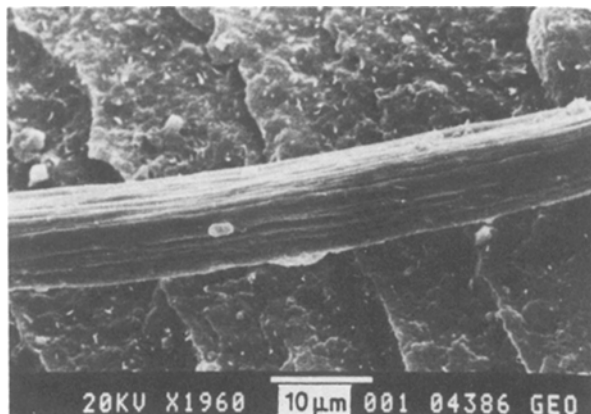

Figure 1 Stainless steel fibre inside the ABS-polymer matrix.

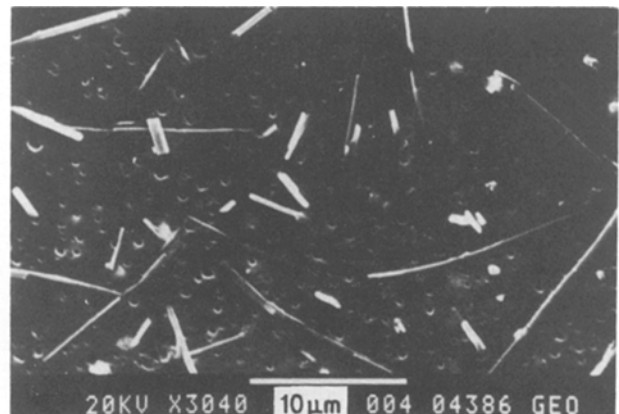

Figure 2 Fibre distribution inside the ABS-polymer matrix.

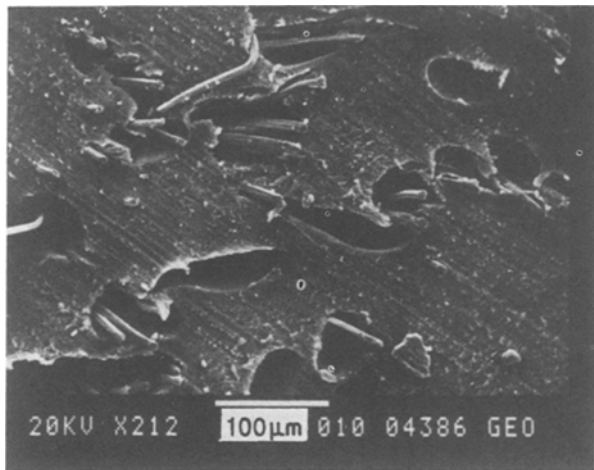

Figure 3 Voids encapsulating the stainless steel fibres.

sheets contain a random distribution of stainless steel fibres which varies from one sheet to another.

Characterization of this material is done via a set of measurements performed at microwave frequencies for the impedance, IL, and RL. The impedance of this specimen, i.e.  $Z_s = R + jX$  in ohms, is measured using the slotted-line method for different frequencies in the X-band. The IL measurements are carried out by using two methods. The single frequency method is used to determine the IL in the C-band (4–8 GHz) and in the X-band; the measurements are performed on one and two samples. The swept-frequency method (shown in Fig. 4) is used to determine the IL in the X-band, and the IL is computed by comparing the response curve of the specimen with the reference lines plotted by the  $XY$  recorder after removing the specimen. All of the previous measurements are done using a rectangular shape specimen. Another specimen is prepared in a right triangular shape and fixed inside the waveguide as shown in Fig. 5. This tapered shape, is used to determine the IL of this specimen. The RL is measured using a 20 dB directional coupler to detect the reflected signal in both the C-band and the X-band.

### 3. Results and discussion

The equivalent impedance,  $Z_s = R + jX$ , of a 1.4 mm thick sample is determined using a Smith chart [8]. The real part  $R$  and the imaginary part  $X$  of the equivalent

impedance are plotted as a function of frequency in Fig. 6a, for absolute values of the equivalent impedance; and in Fig. 6b for the normalized values of the impedance with the waveguide intrinsic impedance for the dominant transverse electric mode taken as the normalization factor. Fig. 7 shows the variation of the equivalent impedance  $|Z_s| = (R^2 + X^2)^{1/2}$  and the phase angle  $\phi = \tan^{-1}(X/R)$  as a function of frequency. The value of  $R$  for this specimen varies from 50 to 105  $\Omega$  while the imaginary part is found to be capacitive and more sensitive than the real part; its value varies from 70 to 22  $\Omega$  over the frequency range. Fig. 7 shows that the value of  $|Z_s|$  for the specimen remains constant ( $\approx 110 \Omega$ ) up to 9.2 GHz, and for frequencies greater than 9.2 GHz its value decreases. This is due to the particular distribution of the fibres inside the material and their interaction with the incident wave. On the other hand, the phase angle  $\phi$  remains nearly constant in the frequency range 9.4 to 11.4 GHz, and has a value of about 40 degrees.

Measured values of the IL as a function of frequency, in the X-band, are shown in Fig. 8. The IL is better than 9 dB for 1.4 mm specimen thickness and its value increases to around 15 dB for two specimens. Also using the swept-frequency method, the same results of the IL could be obtained from Fig. 9. Measured values of the RL are plotted in Fig. 10 and show that the RL is better than 2 dB over the whole X-band. Results of the measurements performed on this material in the frequency range 5 to 8 GHz is shown in Fig. 11. Another set of IL measurements are performed on the specimen shown in Fig. 5 and are plotted in Figs 12, 13 and 14 for the C-band, S-band and X-band respectively. Moreover, Fig. 14 gives the results of the measurements performed on two separate specimens and with the two specimens attached side by side. It is worthwhile mentioning that the difference between the measured values of the IL of the two specimens is due to the random distribution of the stainless steel fibres from one specimen to another. This tapered shape gives higher values for both of the IL and RL. These values suggest that this material could be utilized as an electromagnetic absorbing material, i.e. in building the walls of electromagnetic anechoic chambers.

The behaviour of the IL and RL of the composite

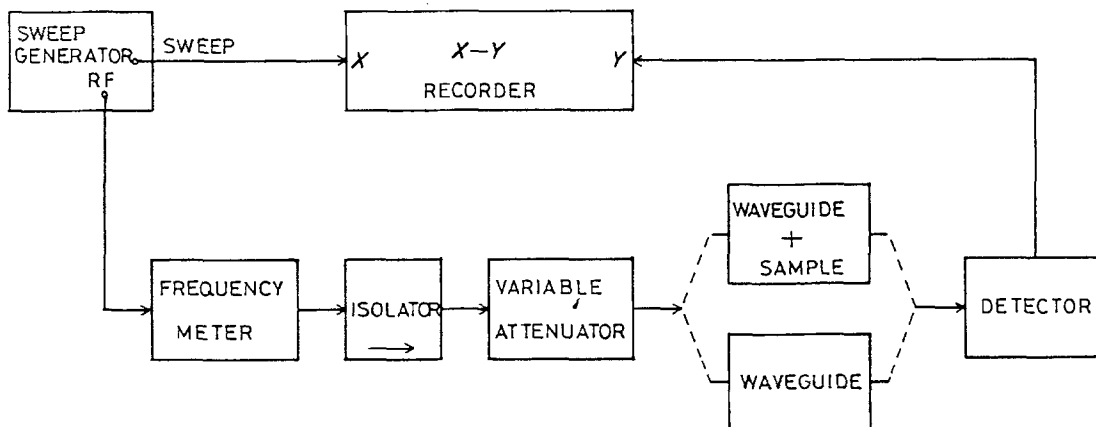

Figure 4 Swept-frequency setup for IL measurement.

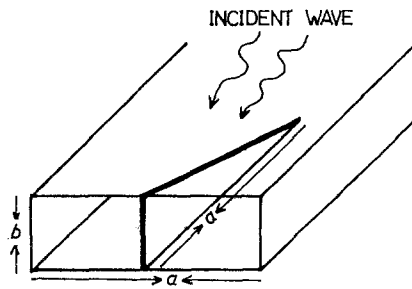

Figure 5 Waveguide containing the tapered specimen.

“Magnex DC” when the specimen has a rectangular shape is caused by the inhomogeneous distribution of the stainless steel fibres inside the ABS-polymer matrix. The fibres in the pressed sheet sample could be considered to be a conducting mesh with different opening sizes. Increasing the specimen thickness would increase the number of fibres intercepting the incident wave and make the network openings between crossed steel fibres in the matrix much smaller

than that of the individual specimen; and consequently the IL is expected to increase for the two specimens in contact as shown in Fig. 8. Hence, it can be concluded that the IL and RL of a rectangular-shape specimen depend on the concentration of fibres inside the polymer matrix as reported elsewhere [2]. Also, the results of the IL and RL measurements show that they are frequency dependent. This dependency is due to the distribution of the conducting fibres inside the specimen. The voids also affect both IL and RL due to their effects on the internal reflection which will result inside the material.

The distribution of the conducting fibres inside this composite material would make it behave more like a conducting mesh, which could be used for electromagnetic shielding purposes. The shielding effectiveness (SE) depends on the thickness of the material, its characteristics and the nature of the incident field [9]. The orientation of the conducting fibres inside this composite material produces openings which affect the coupling of the electromagnetic wave.

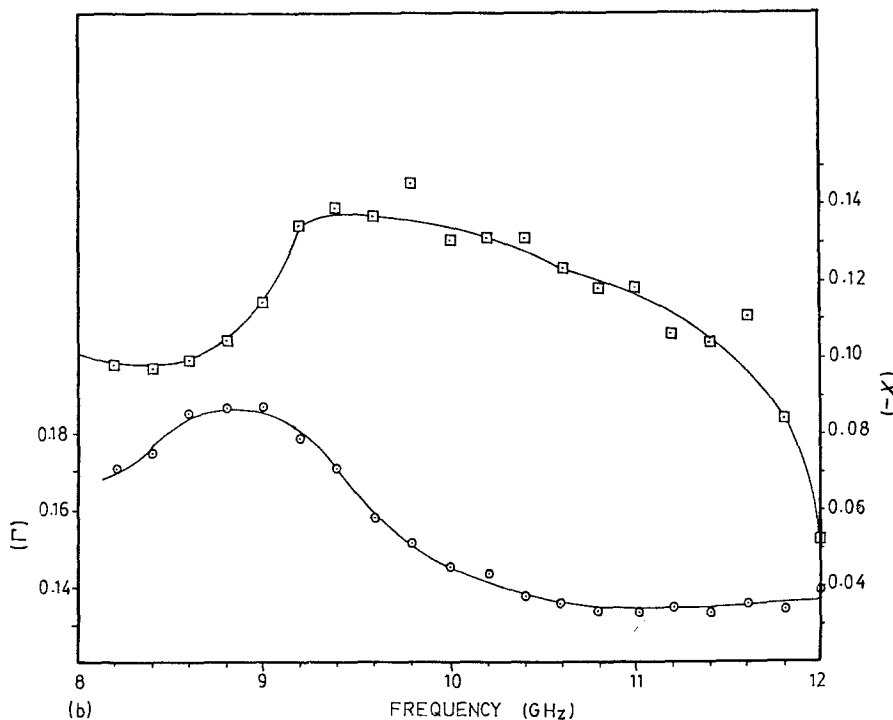
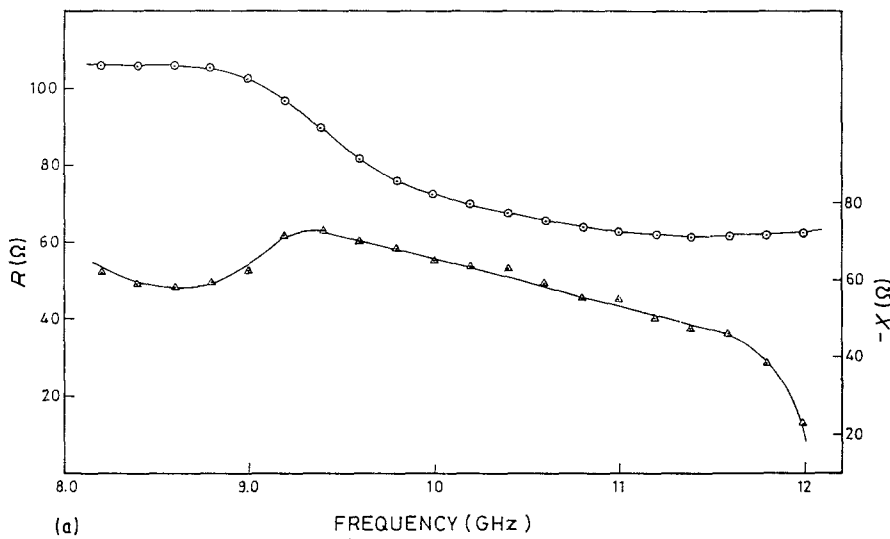

Figure 6 (a) Frequency variation of the real and imaginary parts of the impedance ( $\circ R$ ,  $\Delta X$ ). (b) Frequency-dependence of the normalized impedance ( $\circ R$ ,  $\square X$ ).

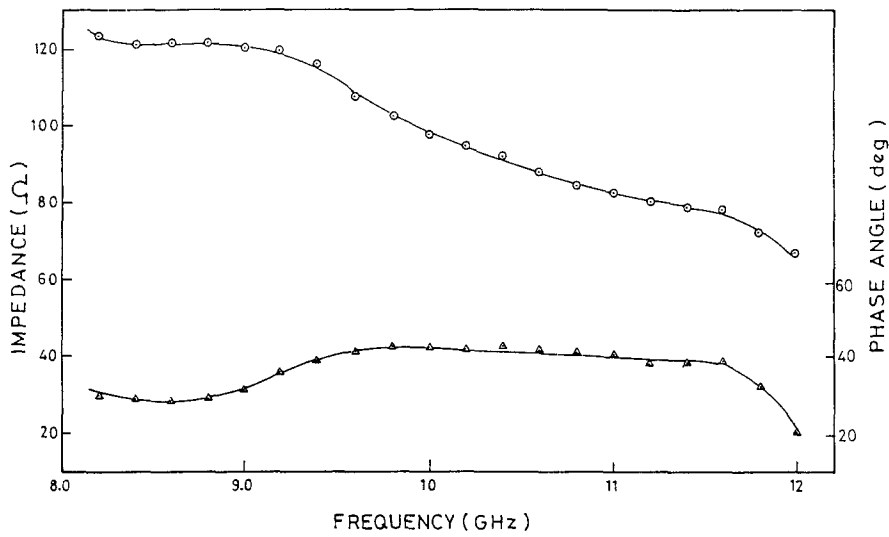

Figure 7 Equivalent impedance ( $Z$ ) ( $\circ$ ) and phase angle ( $\phi$ ) ( $\Delta$ ) dependence on frequency.

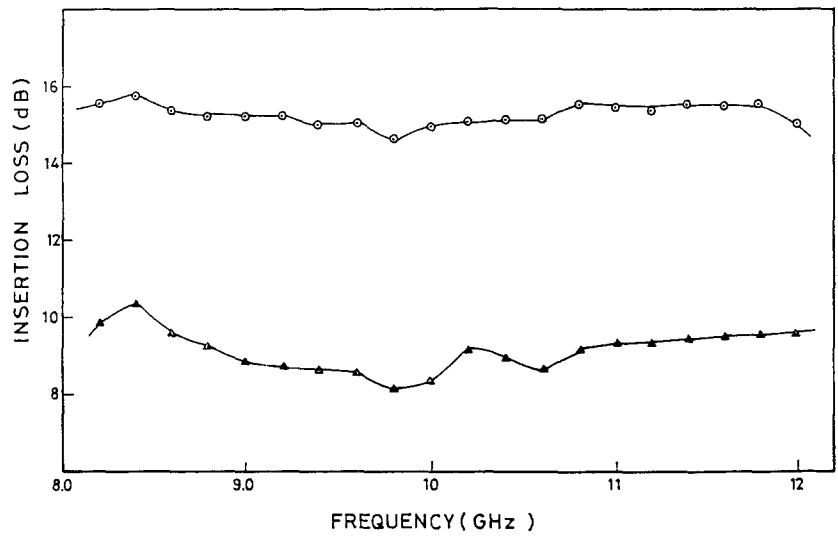

Figure 8 Insertion loss plotted against frequency. ( $\circ$  two samples,  $\Delta$  one sample).

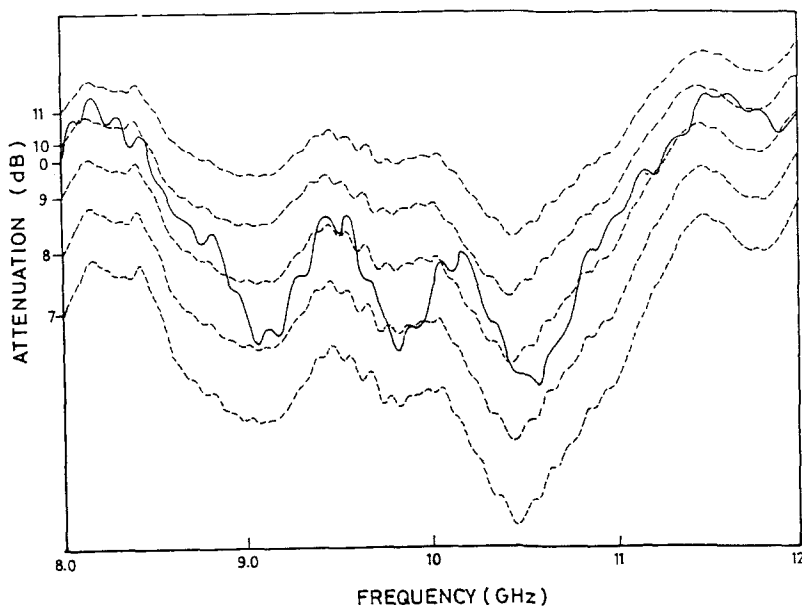

Figure 9 Insertion loss plotted against frequency using swept-frequency technique. (—) Specimen curve, (---) calibration curve.

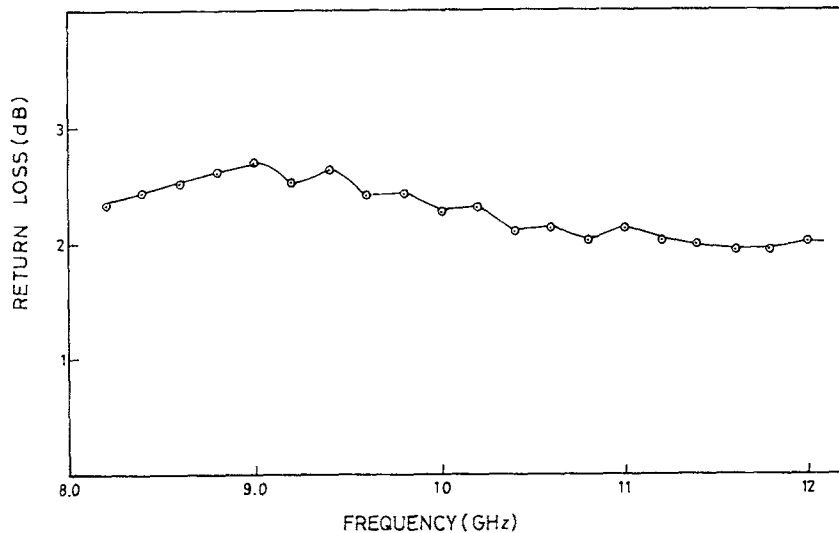

Figure 10 The return loss plotted against frequency.

If the openings are electrically small then the coupling is mainly due to the tangential magnetic field and the electric field component normal to the specimen plane.

Evaluation of the SE of materials is carried out by utilizing two antennae facing each other; placed either close to each other (near field region) or far away from each other (far field region). In the latter case, the wave front is incident on the specimen with different incident angles. Also, a coaxial transmission line holder is utilized. In this case a TEM wave is produced with the wave front incident normally on the specimen. However, utilizing waveguides will result in a wave front with the incident angle, with respect to the normal of the plane of the specimen, ranging from  $55^\circ$  for 8 GHz to  $23^\circ$  for 12 GHz. The value of the SE in this case is evaluated based on the following parameters.

- (i) The absorption inside the 1.4 mm thick specimen which is found to be better than 3 dB over the whole X-band range.
- (ii) The reflection loss of the specimen which is found to be around 5 dB.
- (iii) The effect of multiple reflection which is found to be less than 3 dB.

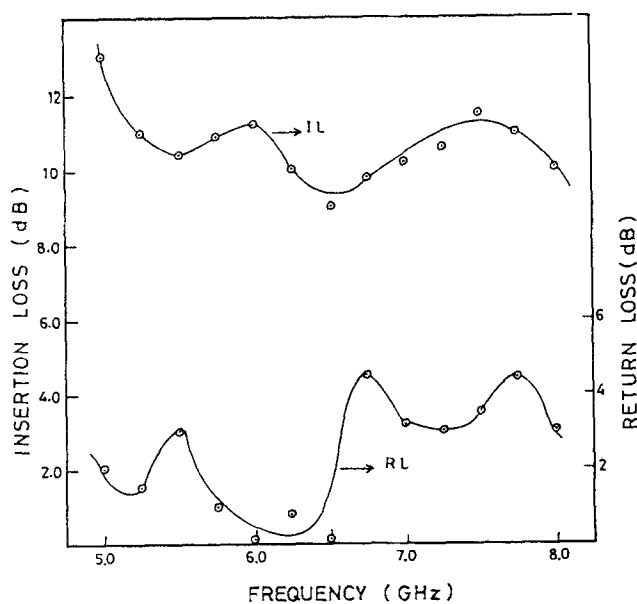

Figure 11 Variation of IL, and RL with frequency.

These values are deduced from a different set of measurements performed on this composite material. The SE is given as the sum of these three parameters, i.e. around 11 dB. It should be noticed that the SE will be approximately doubled by doubling the specimen thickness. Also its value is expected to increase as a function of the concentration of the stainless steel fibres inside the specimen. In short, the SE of this composite material is influenced by the orientation of the fibres inside the material, the incident electric field, the opening size, and the properties of the material.

The measured values of the IL for the tapered shape specimen suggest that it could be used as a waveguide termination. Its orientation in the waveguide with respect to the incident field gives high values for the IL [10, 11]; and the utilization of this material for building electromagnetic absorbent walls is feasible.

#### 4. Conclusion

In this paper, results of the measurements of the equivalent impedance, insertion and return losses performed on the composite material "Magnex DC", are presented. This material contains randomly distributed conducting fibres inside it. This fibre concentration and the composite material characteristics affect the values of the equivalent impedance, IL, and RL. The equivalent impedance of the "Magnex DC"

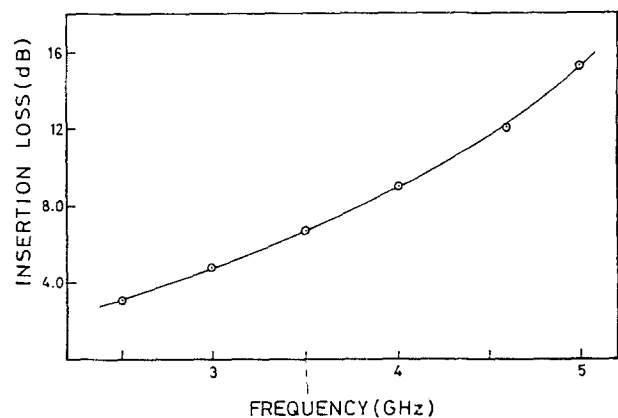

Figure 12 Variation of insertion loss with frequency of the tapered sample.

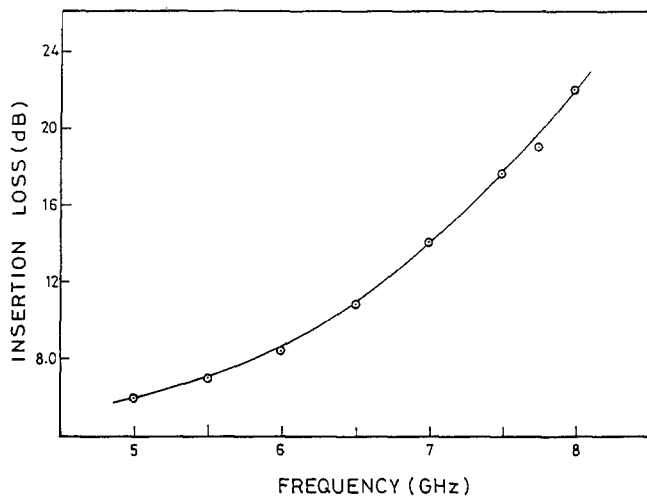

Figure 13 Variation of the insertion loss with frequency for the tapered sample.

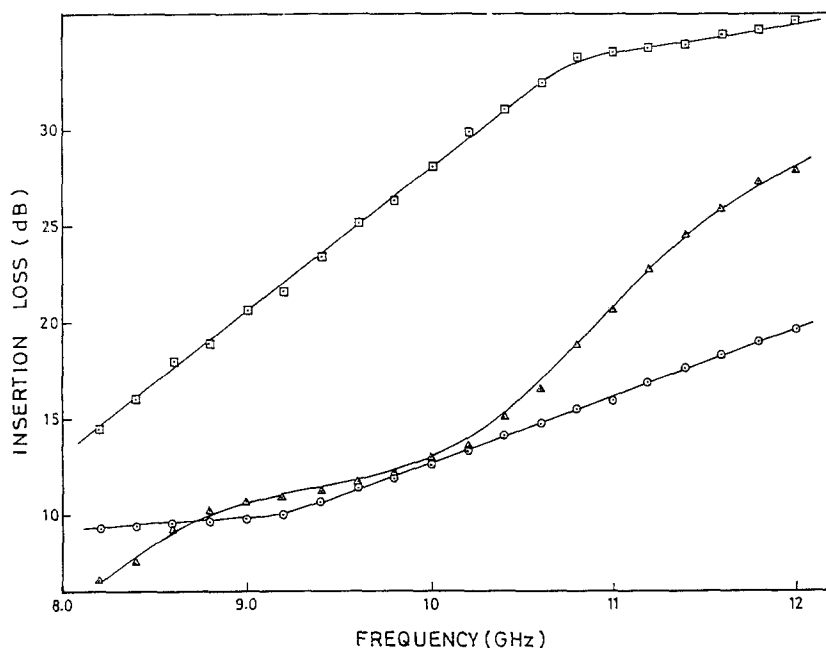

Figure 14 Variation of the IL with frequency for tapered specimens. (○ first sample, △ second sample, □ the two samples).

composite is found to be capacitive and with its reactance is less than its ohmic loss resistance. The evaluation of the shielding effectiveness for this material has been introduced. Measurements of the IL for a tapered shape specimen indicate that it is directly proportional to the frequency. Finally, it can be concluded that this composite material is very promising for both shielding purposes and for the construction of electromagnetic absorbent walls.

## References

1. D. M. BIGG, *J. Reology* **25** (1984) 501.
2. S. RADHAKRISHNAN, *J. Mater. Sci. Lett.* **4** (1985) 1445.
3. PING SHENG, *Phys. Rev. B.* **21** (1980) 2180.
4. D. M. BIGG, W. MIRICK and D. E. STUTZ, *Poly.*

*Testing* **5** (1985) 169.

5. D. M. BIGG, "The Effect of Compounding on the Conductive Properties of EMI Shielding Compounds", Proceedings of the 15th Akron Polymer Conference on Advances in Polymer Processing, University of Akron, 24-25 May, 1984.
6. H. KUWAHARA, Y. RADIO and H. FURUTA, *Proc. IEEE* **650** (1977) 1412.
7. Diamond Shamrock Corp., Material Sheet Data, Ohio, 1983.
8. T. S. LAVERGHETTA, "Microwave Measurement and Techniques", (Artech House, Inc., Washington, 1981).
9. P. F. WILSON, J. W. ADAMS and M. T. MA, *Proc. IEEE* **74** (1986) 112.
10. Z. Q. BAKER, MSc Thesis, University of Jordan (1987).
11. R. E. COLLIN, "Foundation for Microwave Engineering", (McGraw-Hill, New York, 1966).

Received 23 August  
and accepted 17 December 1987